

## An innovative navigator for the next stage of evolution



smart business partner

### High Productivity

The MFP delivers a fast output of 70 ppm\*<sup>1</sup> in colour and 76 ppm\*<sup>1</sup> in black/white—even for paper as thick as 220 g/m<sup>2</sup>. And if toner runs out during a print job, the MFP continues printing your documents while you change the toner cartridge.

### Versatile Paper Handling

This MFP supports a wide range of paper types and sizes, including standard formats up to SRA3/A3W as well as extra-long and custom sizes. The main unit handles paper—including envelopes and the like—up to 300 g/m<sup>2</sup>. The optional inserter supports heavier media up to 360 g/m<sup>2</sup>.

### All the Needed Finishing Options

Finishing options are available for all your common needs—there's an inserter, a folding unit, four types of finisher, and a trimming module. These let you easily create professional-looking direct mail, handouts, booklets, brochures, and more.

### Reliable Paper Feeding and Output

The MFP's finishing options are designed for smooth paper handling. The inserter has a double-feed detection option and an air-feed system to prevent multiple sheets from feeding at once and to minimise paper jams. Some finishers include a built-in air-feed system and paper joggers that help to ensure neatly aligned output stacks.

### Fiery® Server (option)

You can pair the MFP with an embedded Fiery server to manage a busy printing environment. For example, you could use the Sharp printer driver for standard text documents and the Fiery printer driver for graphic-rich documents. You need to register your paper settings only once—the settings on the Fiery server are automatically reflected on the Sharp MFP, and vice versa.

### Smart Scanning

Simply tap the Auto Set button and the MFP will automatically determine the optimal resolution, gradation, and compression rate for your scan jobs. It also automatically reorients pages right side up and corrects any skewed sheets.

### High-Performance DSPF

The DSPF (duplex single pass feeder) scans both pages of two-sided documents in one pass—in batches of up to 300 sheets. With scanning speeds of up to 300 opm\*<sup>2</sup> (two-sided), the MFP is quick to finish even large jobs. The DSPF stops automatically when sheets are not fed in straight. It can also stop when two or more sheets are fed at once. A dedicated business card feeder on the DSPF scans batches of up to 150 cards.

### Cloud Connectivity\*<sup>3</sup>

From the MFP's control panel, you can upload to or print from various cloud-based services. Apps for these services can be installed on the MFP via Sharp's Application Portal, and update alerts ensure that you're always using the latest versions. Single sign-on gives you easy access to your chosen cloud services—no need to re-enter credentials each time you reconnect to the same service. The MFP also supports Microsoft Entra ID, a secure cloud-based service for managing identities and controlling device access. Token-based authentication gives you safe and easy access to any Microsoft service with a single login.

### 10.1-Inch Full-Flat Touchscreen

With a variety of functions accessible via simple, intuitive icons, MFP operation is smooth and easy. The control panel shows the state of your MFP, displaying current operation and notifications for things like paper, toner, and maintenance.

### Solid Security

The MFP has multiple levels of security to keep the device—and your precious data—secure. When booting up, the MFP checks for any anomalies in the BIOS firmware. If it finds a problem, it aborts the startup and launches an automatic BIOS recovery. If there are other firmware-related issues, the MFP will attempt recovery to protect the system. The MFP can also protect itself and connected devices from virus attacks (option). It scans for viruses and prevents them from being transmitted to other devices, such as PCs and smartphones.

\*1: A4 (8 1/2" x 11"), long-edge feeding. \*2: Originals per minute; when feeding A4 (8 1/2" x 11") sheets. \*3: In some countries/regions, optional equipment is required.

# PROFESSIONAL-QUALITY IN-LINE FINISHING OPTIONS

A range of finishing options work to automate time-consuming finishing tasks. Options are available to suit a variety of workplaces and applications.

Features	MX-FN34 Finisher	BP-FN19 Saddle Stitch Finisher	BP-FN20 Finisher	BP-FN20 Finisher	BP-FN21 Saddle Stitch Finisher	BP-FN21 Saddle Stitch Finisher
				+	+	+
				MX-FD10 Folding Unit		MX-FD10 Folding Unit
Stapling	✓	✓	✓	✓	✓	✓
Stapleless stapling	✓	✓				
Manual stapling	✓	✓				
Punching*1	✓	✓	✓	✓	✓	✓
Saddle folding		✓			✓	✓
Multiple saddle folding		✓			✓	✓
Saddle stitching		✓			✓	✓
Half-folding				✓		✓
Z-folding				✓		✓
Z-folding + Stapling				✓		✓
C-folding		✓		✓		✓
Mutiple C-folding		✓				
Accordion folding				✓		✓
Double folding				✓		✓
Trimming*2					✓	✓
Insertion*3			✓	✓	✓	✓

\*1: Requires optional punch module. \*2: Requires optional trimming module. \*3: Requires optional inserter.

### Stapling

Rear corner    Front corner    2-point side

### Punching

2-hole punching    3-hole punching    4-hole punching    4-hole wide punching

### Stapleless Stapling

### Saddle Folding/Stitching

Saddle fold    Multiple saddle fold    Saddle stitch

### Trimming

### Folding

Half-fold    Z-fold    C-fold    Mutiple C-fold    Accordion fold    Double fold

### Insertion

Cover    Inner page

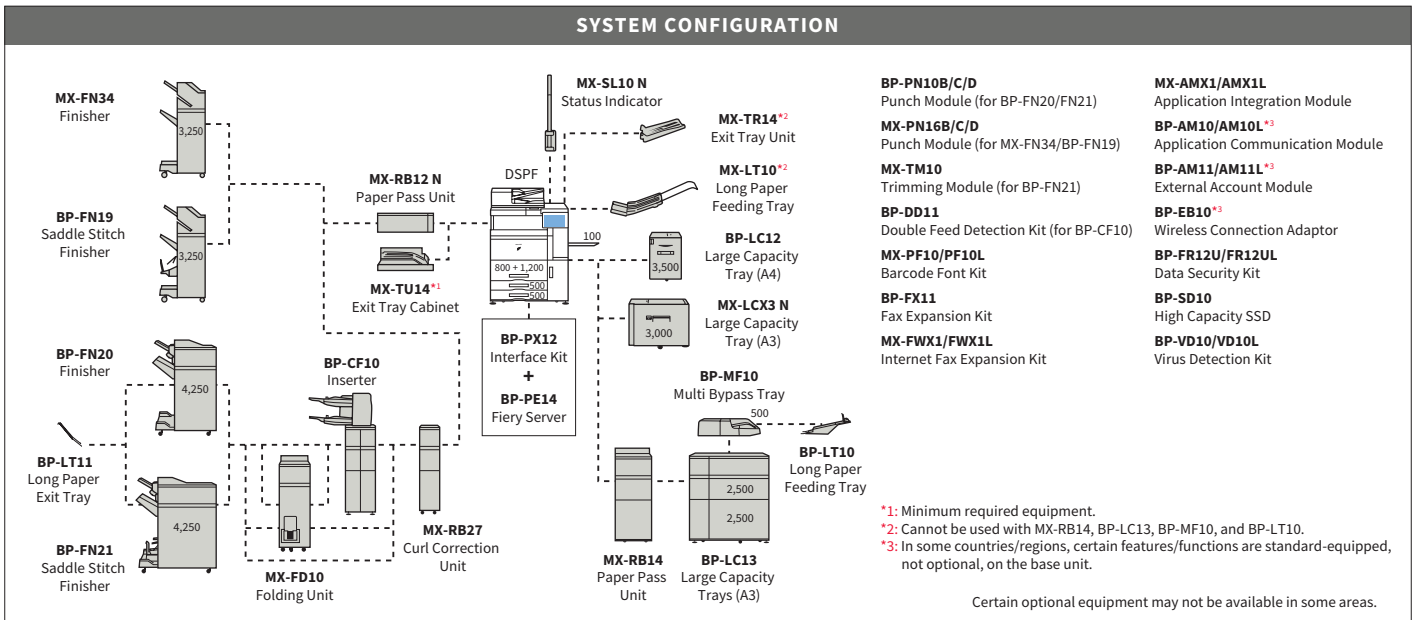

# SPECIFICATIONS FOR OPTIONAL EQUIPMENT

## MX-FN34 Finisher

Paper size	Non offset	SRA3/A3W to A6** (13" x 19" to 5 1/2" x 8 1/2") Custom sizes up to 330 x 488 mm (13" x 19.2")
	Offset/staple	A3 to B5* (11" x 17" to 8 1/2" x 11")
	Stapleless staple	A3, A4** (11" x 17", 8 1/2" x 11")
Paper weight	Non offset/offset/staple	55 g/m <sup>2</sup> to 300 g/m <sup>2</sup> (13 lbs bond to 110 lbs cover)
	Stapleless staple	55 g/m <sup>2</sup> to 105 g/m <sup>2</sup> (13 lbs bond to 28 lbs bond)
Paper capacity	Top tray	250 sheets (A4*, B5*, A5**, A6**)
	Finisher tray (Non offset)	125 sheets (SRA3, A3W, A3, B4, SRA4, A4W, A4**, B5**)
		3,000 sheets (A4*, B5*)
		1,500 sheets (SRA3, A3W, A3, B4, SRA4, A4W, A4**, B5**, A5**)
		750 sheets (A6**)
	(Offset)	3,000 sheets (A4*, B5*), 1,500 sheets (A3, B4, A4*)
	(Staple)	200 sets or 3,000 sheets (A4*, B5*)
		100 sets or 1,500 sheets (A3, B4, A4*)
	(Stapleless staple)	200 sets (A4), 100 sets (A3)
Stapling capacity*	Staple	65 sheets (A4*, B5*), 30 sheets (A3, B4, A4*)
	Stapleless staple*	10 sheets (A4*), 5 sheets (A3)
	Manual staple	Total paper thickness 9 mm or less (65 sheets)
Staple position	Staple mode	3 locations (front, rear, or 2-point stapling)
	Stapleless staple mode	1 location (rear)
	Manual staple mode	1 location
Power requirements		Supplied by main unit
Dimensions	With tray stored	533 x 653 x 1,103 mm (W x D x H)
	With tray extended	635 x 653 x 1,167 mm (W x D x H)
Weight (approx.)		33 kg

## BP-FN19 Saddle Stitch Finisher

Paper size	Non offset	SRA3/A3W to A6** (13" x 19" to 5 1/2" x 8 1/2") Custom sizes up to 330 x 488 mm (13" x 19.2")
	Offset/staple	A3 to B5* (11" x 17" to 8 1/2" x 11")
	Stapleless staple	A3, A4** (11" x 17", 8 1/2" x 11")
Paper weight	Non offset/offset/staple	55 g/m <sup>2</sup> to 300 g/m <sup>2</sup> (13 lbs bond to 110 lbs cover)
	Saddle stitch/saddle fold/C-fold	55 g/m <sup>2</sup> to 256 g/m <sup>2</sup> (13 lbs bond to 140 lbs index)
	Stapleless staple	55 g/m <sup>2</sup> to 105 g/m <sup>2</sup> (13 lbs bond to 28 lbs bond)
Paper capacity	Top tray	250 sheets (A4*, B5*, A5**, A6**)
	Finisher tray (Non offset)	125 sheets (SRA3, A3W, A3, B4, SRA4, A4W, A4**, B5**)
		3,000 sheets (A4*, B5*)
		1,500 sheets (SRA3, A3W, A3, B4, SRA4, A4W, A4**, B5**, A5**)
		750 sheets (A6**)
	(Offset)	3,000 sheets (A4*, B5*), 1,500 sheets (A3, B4, A4*)
	(Staple)	200 sets or 3,000 sheets (A4*, B5*)
		100 sets or 1,500 sheets (A3, B4, A4*)
	(Stapleless staple)	200 sets (A4), 100 sets (A3)
	Saddle stitch tray	25 sets of 1-5 sheets, 15 sets of 6-10 sheets, 10 sets of 11-20 sheets
	(C-fold)	25 sets of 1 sheet, 10 sets of 2-3 sheets, 5 sets of 4-5 sheets
Stapling capacity*	Staple	65 sheets (A4*, B5*), 30 sheets (A3, B4, A4*)
	Stapleless staple*	10 sheets (A4*), 5 sheets (A3)
	Manual staple	Total paper thickness 9 mm or less (65 sheets)
Staple position	Staple mode	3 locations (front, rear, or 2-point stapling)
	Stapleless staple mode	1 location (rear)
	Manual staple mode	1 location
Power requirements		Supplied by main unit
Dimensions	With tray stored	533 x 653 x 1,103 mm (W x D x H)
	With tray extended	635 x 653 x 1,167 mm (W x D x H)
Weight (approx.)		57 kg

## BP-FN20 Finisher

Paper size	Non offset	SRA3/A3W to A6** (13" x 19" to 5 1/2" x 8 1/2") Custom sizes up to 330 x 488 mm (13" x 19.2")
	Offset	SRA3/A3W to B5* (13" x 19" to 8 1/2" x 11")
	Staple	A3 to B5 (11" x 17" to 8 1/2" x 11")
Paper weight	Non offset/offset/staple	52 g/m <sup>2</sup> to 360 g/m <sup>2</sup> (13 lbs bond to 130 lbs cover)
Paper capacity	Top tray	250 sheets (A4*, B5*, A5**, A6**)
	Finisher tray (Non offset)	125 sheets (SRA3, A3W, A3, B4, SRA4, A4W, A4**, B5**)
		1,500 sheets (SRA3, A3W, A3, B4, A5**), 1,000 sheets (A6**)
	(Offset)	4,000 sheets (A4*, B5*), 2,000 sheets (SRA4, A4**)
		1,500 sheets (SRA3, A3, B4)
Stapling capacity*		100 sheets (A4, B5), 65 sheets (A3, B4)
Staple position		3 locations (front, rear, or 2-point stapling)
Power consumption (max.)		390 W, 700 W with MX-FD10
Power requirements		AC 100-240 V, 2.9 A, 50/60 Hz
Dimensions	With tray stored	704 x 800 x 1,052 mm (W x D x H)
	With tray extended	882 x 800 x 1,142 mm (W x D x H)
Weight (approx.)		82 kg

## BP-FN21 Saddle Stitch Finisher

Paper size	Non offset	SRA3/A3W to A6** (13" x 19" to 5 1/2" x 8 1/2") Custom sizes up to 330 x 488 mm (13" x 19.2")
	Offset	SRA3/A3W to B5* (13" x 19" to 8 1/2" x 11")
	Staple	A3 to B5 (11" x 17" to 8 1/2" x 11")
Paper weight	Non offset/offset/staple	52 g/m <sup>2</sup> to 360 g/m <sup>2</sup> (13 lbs bond to 130 lbs cover)
	Saddle stitch/saddle fold	55 g/m <sup>2</sup> to 300 g/m <sup>2</sup> (16 lbs bond to 110 lbs cover)
Paper capacity	Top tray	250 sheets (A4*, B5*, A5**, A6**)
	Finisher tray (Non offset)	125 sheets (SRA3, A3W, A3, B4, SRA4, A4W, A4**, B5**)
		4,000 sheets (A4*, B5*), 2,000 sheets (SRA4, A4**, B5**)
	(Offset)	1,500 sheets (SRA3, A3W, A3, B4, A5**), 1,000 sheets (A6**)
		4,000 sheets (A4*, B5*), 2,000 sheets (SRA4, A4**)
		1,500 sheets (SRA3, A3, B4)
	(Saddle fold)	150 sheets (A3), 50 sheets (A4*)
	Saddle stitch tray	25 sets of 2-5 sheets, 15 sets of 6-10 sheets, 10 sets of 11-15 sheets, 5 sets of 16-20 sheets
Stapling capacity*		100 sheets (A4, B5), 65 sheets (A3, B4)
Staple position		3 locations (front, rear, or 2-point stapling)
Power consumption (max.)		420 W, 730 W with MX-FD10
Power requirements		AC 100-240 V, 3.2 A, 50/60 Hz
Dimensions	With tray stored	887 x 800 x 1,052 mm (W x D x H)
	With tray extended	1,065 x 800 x 1,142 mm (W x D x H)
Weight (approx.)		131 kg

## MX-TM10 Trimming Module (for BP-FN21)

Paper size	SRA3/A3W to A4** (13" x 19" to 8 1/2" x 11")
	Custom sizes up to 330 x 488 mm (13" x 19.2")
Paper weight	60 g/m <sup>2</sup> to 300 g/m <sup>2</sup> (16 lbs bond to 110 lbs cover)
Acceptable number of sheets*	2-20 sheets (60 g/m <sup>2</sup> to 81.4 g/m <sup>2</sup> )
	2-10 sheets (more than 81.4 g/m <sup>2</sup> to 105 g/m <sup>2</sup> )
	2-3 sheets (more than 105 g/m <sup>2</sup> to 220 g/m <sup>2</sup> )
Trim width	2 mm to 20 mm in 0.1 mm increments
Weight (approx.)	32 kg

## Punch Modules

Model name	For the MX-FN34/BP-FN19	MX-PN16B	MX-PN16C	MX-PN16D
	For the BP-FN20/FN21	BP-PN10B	BP-PN10C	BP-PN10D
Number of holes		3/2	4/2	4 (wide)
Paper weight	MX-PN16B/C/D	55 g/m <sup>2</sup> to 300 g/m <sup>2</sup> (13 lbs bond to 110 lbs cover)		
	BP-PN10B/C/D	52 g/m <sup>2</sup> to 300 g/m <sup>2</sup> (13 lbs bond to 110 lbs cover)		
Power requirements	Supplied by MX-FN34/BP-FN19/FN20/FN21 finisher			

## MX-FD10 Folding Unit

Folding mode	Z-fold, C-fold, Accordion-fold, Double-fold, Half-fold
Paper size	Z-/Half-fold** A3 to A4** (11" x 17" to 8 1/2" x 11")
	C-/Accordion-/Double-fold A4*, 8 1/2" x 11"
Paper capacity	Z-fold** 30 sheets (A3, B4), 10 sheets (A4)
	Half-fold** 10 sheets (A4*)
	C-/Accordion-fold 40 sheets (A4*)
	Double-fold 25 sheets (A4*)
Paper weight	52 g/m <sup>2</sup> to 105 g/m <sup>2</sup> (13 lbs bond to 28 lbs bond)
Power requirements	Supplied by BP-FN20/FN21 finisher
Dimensions	336 x 793 x 1,050 mm (W x D x H)
Weight (approx.)	66 kg

## MX-RB27 Curl Correction Unit

Paper size	SRA3/A3W to A6** (13" x 19" to 5 1/2" x 8 1/2") Custom sizes up to 330 x 488 mm (13" x 19.2")
Paper weight	55 g/m <sup>2</sup> to 300 g/m <sup>2</sup> (13 lbs bond to 110 lbs cover)
Power requirements	Supplied by main unit
Dimensions	214 x 762 x 986 mm (W x D x H)
Weight (approx.)	19 kg

## BP-CF10 Inserter

Paper size	SRA3/A3W to A6** (13" x 19" to 5 1/2" x 8 1/2") Custom sizes up to 330 x 488 mm (13" x 19.2")
Paper weight	52 g/m <sup>2</sup> to 360 g/m <sup>2</sup> (13 lbs bond to 130 lbs cover)
Paper capacity	Upper/lower tray 200 sheets/each
Power requirements	Supplied by main unit
Dimensions	740 x 730 x 1,350 mm (W x D x H)
Weight (approx.)	60 kg

## BP-LC12 Large Capacity Tray (A4)

Paper size	A4*, B5* (8 1/2" x 11")
Paper weight	60 g/m <sup>2</sup> to 220 g/m <sup>2</sup> (16 lbs bond to 80 lbs cover)
Paper capacity	3,500 sheets
Power requirements	Supplied by main unit
Dimensions	376 x 575 x 523 mm (W x D x H)
Weight (approx.)	29 kg

## MX-LCX3 N Large Capacity Tray (A3)

Paper size	SRA3/A3W to B5* (12" x 18" to 8 1/2" x 11")
Paper weight	60 g/m <sup>2</sup> to 220 g/m <sup>2</sup> (16 lbs bond to 80 lbs cover)
Paper capacity	3,000 sheets
Power requirements	Supplied by main unit
Dimensions	670 x 570 x 525 mm (W x D x H)
Weight (approx.)	50 kg

## BP-LC13 Large Capacity Trays

Paper size	SRA3/A3W to B5 (13" x 19" to 7 1/2" x 10 1/2") Custom sizes up to 330 x 488 mm (13" x 19.2")
Paper weight	55 g/m <sup>2</sup> to 300 g/m <sup>2</sup> (13 lbs bond to 110 lbs cover)
Paper capacity	Upper/lower tray 2,500 sheets/each
Power consumption (max.)	900 W
Power requirements	AC 220-240 V, 4 A, 50/60 Hz
Dimensions	895 x 763 x 986 mm (W x D x H)
Weight (approx.)	132 kg

## BP-MF10 Multi Bypass Tray (for BP-LC13)

Paper size	SRA3/A3W to A5** (13" x 19" to 5 1/2" x 8 1/2") Custom sizes up to 330 x 488 mm (13" x 19.2")
Paper weight	55 g/m <sup>2</sup> to 220 g/m <sup>2</sup> (13 lbs bond to 80 lbs cover)
Paper capacity	500 sheets
Power requirements	Supplied by BP-LC13 Large Capacity Trays
Dimensions	With tray stored 690 x 561 x 210 mm (W x D x H)
	With tray extended 864 x 561 x 210 mm (W x D x H)
Weight (approx.)	20 kg

## BP-LT10 Long Paper Feeding Tray (for BP-MF10)

Paper size	Width 100 mm to 305 mm
	Length 489 mm to 1,300 mm
Paper capacity	500 sheets (489 mm to 700 mm long)
	1 sheet (701 mm to 1,300 mm long)
Dimensions	553 x 364 x 142 mm (W x D x H)
Weight (approx.)	5.0 kg

Note: All specifications relating to paper capacity refer to 80 g/m<sup>2</sup> paper.

\*1: Short-edge feeding for A5 and A6 paper. \*2: Short-edge feeding for 7 1/4" x 10 1/2" and 5 1/2" x 8 1/2" paper. \*3: Long-edge feeding. \*4: Short-edge feeding. \*5: Using 80 g/m<sup>2</sup> paper, can include back and front covers (total of 2 sheets) of heaviest paper that can be stapled. \*6: Because no staples are used, the binding strength may vary depending on paper type and usage environment and is not as strong as conventional stapling. \*7: Can include a single cover sheet of 300 g/m<sup>2</sup> or less. \*8: Z-fold and half-fold pages are output to the finisher tray (BP-FN20/FN21).

## SPECIFICATIONS

### General

<b>Type</b>	Console
<b>Engine speed</b>	A4 (8 1/2" x 11") <sup>*1</sup> : Colour max. 70 ppm B/W max. 76 ppm A3 (11" x 17"): Max. 34 ppm SRA3/A3W: Max. 33 ppm
<b>Control panel display</b>	10.1-inch colour LCD touchscreen
<b>Paper size</b>	Max. SRA3/A3W (13" x 19"), min. A6 (5 1/2" x 8 1/2") <sup>*2</sup>
<b>Paper capacity (80 g/m<sup>2</sup>)</b>	Standard: 3,100 sheets (1,200-sheet tray, 800-sheet tray, 500-sheet tray x 2, and 100-sheet multi bypass tray) Maximum: 8,500 sheets (3,000 sheets & optional 2 x 2,500-sheet tray and 500-sheet multi bypass tray)
<b>Paper weight</b>	Tray 1&2: 60 g/m <sup>2</sup> to 105 g/m <sup>2</sup> (16 lbs bond to 28 lbs bond) Tray 3&4: 60 g/m <sup>2</sup> to 300 g/m <sup>2</sup> (16 lbs bond to 110 lbs cover) Multi bypass tray (standard): 55 g/m <sup>2</sup> to 300 g/m <sup>2</sup> (13 lbs bond to 110 lbs cover) Multi bypass tray (BP-MF10): 55 g/m <sup>2</sup> to 220 g/m <sup>2</sup> (13 lbs bond to 80 lbs cover) Large capacity tray (BP-LC12/MX-LCX3 N): 60 g/m <sup>2</sup> to 220 g/m <sup>2</sup> (16 lbs bond to 80 lbs cover) Large capacity trays (BP-LC13): 55 g/m <sup>2</sup> to 300 g/m <sup>2</sup> (13 lbs bond to 110 lbs cover)
<b>Warm-up time<sup>*3</sup></b>	55 sec. <sup>*4</sup>
<b>Memory</b>	6 GB (copy/print shared) 256 GB SSD <sup>*5</sup> Option: 512 GB <sup>*6</sup>
<b>Power requirements</b>	AC 220 V to 240 V, 8 A, 50/60 Hz (10 A plug x 2)
<b>Power consumption (max.)</b>	Max. 3.84 kW (220 V to 240 V)
<b>Dimensions (W x D x H)<sup>*7</sup></b>	845 x 841 x 1,249 mm (33 9/32" x 33 1/8" x 49 3/16")
<b>Weight (approx.)</b>	207 kg (456.4 lbs)

### Copier

<b>Original paper size</b>	Max. A3 (11" x 17")
<b>First copy time<sup>*8</sup></b>	Full colour: 4.8 sec. B/W: 3.7 sec.
<b>Continuous copy</b>	Max. 9,999 copies
<b>Resolution</b>	Scan (colour): 600 x 600 dpi Scan (B/W): 600 x 600 dpi, 600 x 400 dpi Print (colour): 600 x 600 dpi, 9,600 (equivalent) x 600 dpi Print (B/W): 1,200 x 1,200 dpi, 600 x 600 dpi, 9,600 (equivalent) x 600 dpi
<b>Gradation</b>	Equivalent to 256 levels
<b>Zoom range</b>	25% to 400% in 1% increments
<b>Preset copy ratios</b>	Metric: 10 ratios (5R/5E), inch: 8 ratios (4R/4E)

### Scanner

<b>Scan method</b>	Push scan (via control panel) Pull scan (TWAIN-compliant application)
<b>Scan speed<sup>*9</sup> (colour &amp; B/W)</b>	One-sided: Max. 150 originals/min. Two-sided: Max. 300 originals/min.
<b>Resolution</b>	Push scan: 100, 150, 200, 300, 400, 600 dpi Pull scan: 75, 100, 150, 200, 300, 400, 600 dpi 50 dpi to 9,600 dpi via user setting <sup>*10</sup>
<b>File formats</b>	TIFF, PDF, PDF/A-1a, PDF/A-1b, encrypted PDF, XPS, compact PDF <sup>*11</sup> , JPEG <sup>*11</sup> , searchable PDF, OOXML (pptx, xlsx, docx), text (TXT [UTF-8]), rich text (RTF)
<b>Scan destinations</b>	Email/desktop <sup>*12</sup> /FTP server/network folder (SMB)/USB drive/local drive

<sup>\*1</sup>: Long-edge feeding. <sup>\*2</sup>: Only short-edge feeding can be used with A6 (5 1/2" x 8 1/2") paper. <sup>\*3</sup>: In a standard measurement environment. May vary depending on operating conditions and environment.  
<sup>\*4</sup>: When starting the MFP via the power button. 66 seconds when starting via the main power switch. <sup>\*5</sup>: Storage capacity depends on procurement and sourcing status. <sup>\*6</sup>: Replacing the standard-equipped SSD with the optional BP-SD10 increases storage capacity to 512 GB. <sup>\*7</sup>: Including adjusters and protrusions. <sup>\*8</sup>: Long-edge feeding of A4 (8 1/2" x 11") sheets from 2nd paper tray, using document glass, without Auto Colour Selection and Auto Colour mode, MFP in fully ready condition. May vary depending on operating conditions and environment. <sup>\*9</sup>: Based on Sharp's A4 standard chart, using document feeder, long-edge feeding, and factory default settings. Scan speed will vary depending on the type of document and the scan settings.  
<sup>\*10</sup>: Resolution will vary depending on the size of the scanned area. <sup>\*11</sup>: Colour/greyscale only. <sup>\*12</sup>: Requires Network Scanner Tool Lite. <sup>\*13</sup>: Storage capacity will vary depending on the type of document and the scan settings. <sup>\*14</sup>: Some features require optional equipment. <sup>\*15</sup>: In some countries/regions, the optional BP-EB10 is required. Availability of this option varies by country/region. <sup>\*16</sup>: Based on Sharp's standard chart with approx. 700 characters (A4 or 8 1/2" x 11" long-edge feeding) at standard resolution in Super G3 mode, 33,600 bps, JBIG compression.

### Document Filing

<b>Document filing capacity<sup>*13</sup></b>	Main and custom folders: 20,000 pages or 3,000 files Quick file folder: 10,000 pages or 1,000 files
<b>Stored jobs<sup>*14</sup></b>	Copy, print, scan, fax
<b>Storage folders</b>	Quick file folder, main folder, custom folder (max. 1,000 folders)

### Printer

<b>Resolution</b>	1,200 x 1,200 dpi, 600 x 600 dpi, 9,600 (equivalent) x 600 dpi
<b>Interface</b>	USB 2.0 (host, high-speed), USB 3.0 (host, super speed), 10Base-T/100Base-TX/1000Base-T, wireless LAN (IEEE 802.11 a/b/g/n/ac) <sup>*15</sup>
<b>Supported OS</b>	Windows Server 2016, Windows Server 2019, Windows Server 2022, Windows Server 2025, Windows 11, macOS 10.15, 11, 12, 13, 14, 15, 26
<b>Network protocols</b>	TCP/IP
<b>Printing protocols</b>	LPR, Raw TCP (port 9100), POP3 (email printing), HTTP, FTP, IPP, IPP Everywhere, SMB, WSD
<b>PDL</b>	PCL 6 emulation, Adobe PostScript 3
<b>Available fonts</b>	80 fonts for PCL, 139 fonts for Adobe PostScript 3

### Fiery® Server (requires optional BP-PE14 and BP-PX12)

<b>Type</b>	Embedded server
<b>System software</b>	Fiery FS700
<b>Operating system</b>	Linux
<b>CPU</b>	Intel® Pentium® G7400E, 3.7 GHz
<b>Memory</b>	8 GB RAM 500 GB HDD
<b>Resolution</b>	1,200 x 1,200 dpi, 600 x 600 dpi (PS, PCL)
<b>Supported OS</b>	Windows Server 2016, Windows Server 2019, Windows Server 2022, Windows Server 2025, Windows 11, macOS 12, 13, 14, 15, 26
<b>Network protocols</b>	TCP/IP, LDAP, iPrint thru LPR
<b>Interface</b>	Gigabit Ethernet
<b>Printing protocols</b>	LPD, PAP, SMB, port 9100, IPP 1.1, FTP printing, WSD
<b>PDL</b>	Adobe PostScript 3
<b>Available fonts</b>	138 fonts for Adobe PostScript 3
<b>Power requirements</b>	AC 100 V to 240 V, 50/60 HZ
<b>Power consumption</b>	Max. 0.08 kW
<b>Dimensions (W x D x H)</b>	272 x 297 x 90 mm (10 23/32" x 11 45/64" x 3 35/64")
<b>Weight (approx.)</b>	3.8 kg (8.2 lbs)

### Facsimile (requires optional BP-FX11)

<b>Compression method</b>	MH/MR/MMR/JBIG
<b>Communication protocol</b>	Super G3/G3
<b>Transmission time</b>	Less than 3 seconds <sup>*16</sup>
<b>Modem speed</b>	33,600 bps to 2,400 bps with automatic fallback
<b>Transmission resolution</b>	Standard (203.2 x 97.8 dpi) to Ultra Fine (406.4 x 391 dpi)
<b>Recording size</b>	A3 to A5 (11" x 17" to 5 1/2" x 8 1/2")
<b>Memory</b>	4 GB (built-in)
<b>Greyscale levels</b>	Equivalent to 256 levels

• Design and specifications are subject to change without prior notice.  
• Fiery is a registered trademark of Fiery, LLC. Microsoft, Microsoft Entra, Windows, and Windows Server are trademarks of the Microsoft group of companies. Adobe and PostScript are either registered trademarks or trademarks of Adobe in the US and/or other countries. macOS is a trademark of Apple Inc., registered in the US and other countries and regions. Intel and Pentium are trademarks of Intel Corporation or its subsidiaries in the US and/or other countries. All other brand names and product names may be trademarks or registered trademarks of their respective owners.

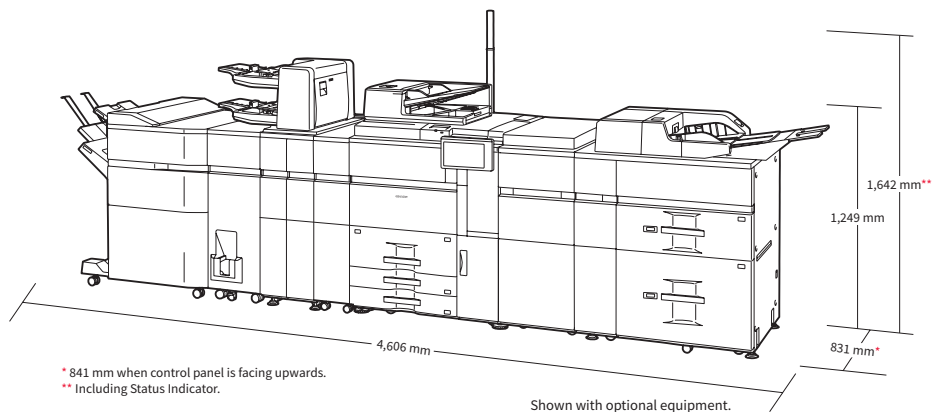

Distributed by: